

# 400-04CV

## The New, Affordable UltraStealth

The affordable, portable UltraMax® 400-04CV delivers a compact and easily transportable package. With fast and easy set-up, this small crusher will deliver a cubicle product no matter what you are crushing. Best of all, the 400-04CV is transportable without permit in most situations.

## 400-04CV *QuikSpecs*®

- Built-in hydraulic/lift leveling system delivers quick set-up and tear-down
- Set up without a crane
- Environmentally tight product design reduces dust during operation
- The solid-steel, 3-bar rotor easily handles limestone and sand & gravel feed material with reduction ratios up to 24:1
- On-board 225 HP diesel engine with 40 kW generator powers all plant functions
- 26" x 12' vibrating grizzly feeder features a proven two-step grizzly.
- Backed by the industry's first 5-year rotor guarantee
- Hydraulic-opening impactor housing offers unobstructed access to crushing chamber and secondary curtain adjustment
- Remote operator's station mounted on operator's platform



UltraMax® 400-04CV



**ULTRAMAX**® IMPACTORS

**Product Specification Sheet**  
**400-04CV Portable Plant Specifications**



**400-04CV Travel Dimensions**

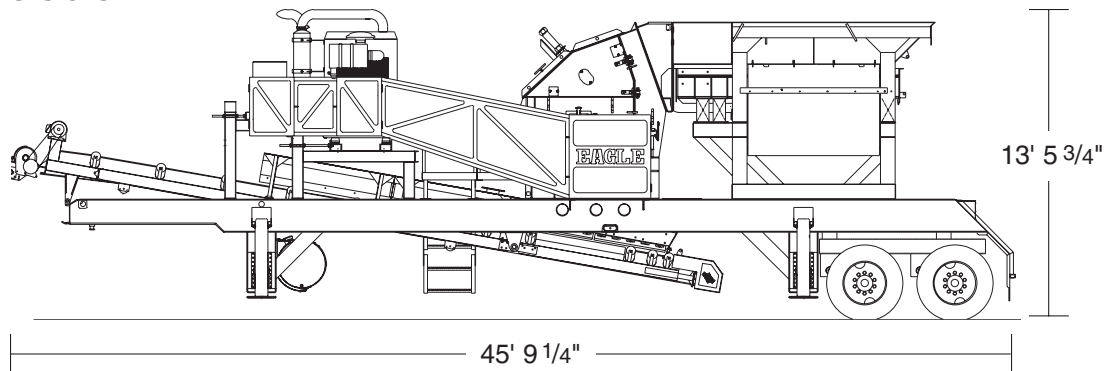

**400-04CV Portable Plant Specifications\***

<b>Impactor</b>	3-stage UltraMax® UM04
<b>Impactor Weight</b>	16,600 lbs.
<b>Plant Weight</b>	59,000 lbs.
<b>Travel Width</b>	8'
<b>Rotor Diameter &amp; Width</b>	40" x 29"
<b>Feed Opening</b>	27" x 32"
<b>Vibrating Grizzly Feeder Dimensions</b>	26" x 12'
<b>Feed Hopper Capacity</b>	7 cubic yards
<b>Grizzly Bars</b>	Two-step, 30" long bars with various spacing
<b>On-Plant Power Supply</b>	225 HP diesel engine and 40 kW generator
<b>Hydraulic Lift/Leveling System</b>	On-board, gas-powered; also used for secondary curtain settings and crushing chamber access

\*Design specifications subject to change without notice.

**UltraMax® Impactor Models and Specifications**

<b>UM69</b>	56 x 68	69 x 42	400-600	60,200
<b>UM45</b>	50 x 56	56 x 35	300-400	38,700
<b>UM25</b>	47 x 47	48 x 34	150-300	32,500
<b>UM15</b>	44 x 41	42 x 32	150-200	27,500
<b>UM05</b>	40 x 33	33 x 32	75-150	19,500
<b>UM04</b>	40 x 29	27 x 32	60-100	16,600
	Diameter x Width	Width x Height		
<b>Model</b>	<b>Rotor</b> (Inches)	<b>Feed Opening</b> (Inches)	<b>Power Required</b> (HP)	<b>Approx. Weight</b> (Lbs)

**ATTENTION:** Eagle Crusher Company designs a range of impactors. The capacities vary based on feed size, feed rate, physical characteristics of feed material, environmental conditions, operator training and proficiency, blow bar gap settings, and conditions of wear parts.

**Aggregate • Sand & Gravel • C&D Debris • Recycle Concrete • Recycle Asphalt**  
 P.O. Box 537, Galion, OH 44833 • 419-468-2288 • fax: 419-468-4840 • email: sales@eaglecrusher.com

**Call 800-25-EAGLE**  
**or visit [www.eaglecrusher.com](http://www.eaglecrusher.com)**