

1000-15CV Power Package

Versatile Crushing & Screening Combination Plant

With increased engine horsepower and generator capacities, the UltraMax® 1000-15CV aggregate/recycling plant gives you more power and the versatility you need for increased production and profitability. The 1000-15CV Power Package featuring the UM15 impactor includes a versatile solid-steel, 3-bar rotor that easily handles heavy concrete, asphalt, shot rock, limestone, and sand & gravel feed materials with reduction ratios up to 24:1. A hydraulic lift/leveling system and air-ride suspension delivers superior 3-load portability and fast set-up.

1000-15CV *QuikSpecs*®

- Powerful on-board 375 HP diesel engine with 175 kW generator to operate all package components
- 6' x 20' triple-deck screening plant separates up to three cubical spec products simultaneously (optional)
- Chevron-cleated, 30" x 50' return conveyor plus three stockpiling conveyors (optional)
- Operational as an open or closed-circuit crushing plant
- 11-cubic yard feed hopper easily accepts aggregate or recycle material from 3.5 to 5-yard loader buckets or excavator
- Adjustable primary and secondary curtains allow precise product gradation control
- Backed by the industry's first 5-year rotor guarantee
- Hydraulic-opening impactor housing offers unobstructed access to crushing chamber and secondary curtain adjustment
- Remote operator's station mounted on operator's platform



UltraMax® 1000-15CV
Power Package



ULTRAMAX® IMPACTORS

Product Specification Sheet
1000-15CV Portable Plant Specifications

EAGLE CRUSHER
 COMPANY, INCORPORATED

1000-15CV Travel Dimensions

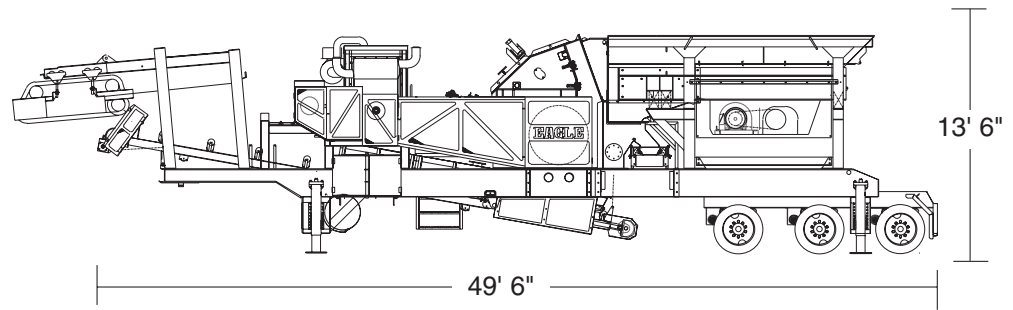

1000-15CV Power Package Portable Plant Specifications*

Impactor	3-stage UltraMax® UM15
Impactor Weight	27,500 lbs.
Plant Weight	87,600 lbs.
Travel Width	11' 11"
Production Capacities	Call factory for capacity in your application
Rotor Diameter & Width	44" x 41"
Feed Opening	42" x 32"
Vibrating Grizzly Feeder Dimensions	16" x 39" with 5' tapered step grizzly
Feed Hopper Capacity	11 cubic yards/14 tons
Grizzly Bars	Two-step, 30" long bars with various spacing
Separate Screening Plant (optional)	Horizontal 6' x 20' triple-deck
Discharge System	36" wide discharge conveyor
Return Conveyor (optional)	30" x 50' chevron-cleated conveyor for returning oversize to crusher
Stockpiling Conveyors (optional)	Three (3) 30" x 50' smooth belt conveyors
On-Plant Power Supply	375 HP diesel engine and 175 kW generator
Hydraulic Lift/Leveling System	On-board, gas-powered for crushing and screening plants; also used for secondary curtain settings and crushing chamber access

* Design specifications subject to change without notice.

UltraMax® Impactor Models and Specifications

UM69	56 x 68	69 x 42	400-600	60,200
UM45	50 x 56	56 x 35	300-400	38,700
UM25	47 x 47	48 x 34	150-300	32,500
UM15	44 x 41	42 x 32	150-200	27,500
UM05	40 x 33	33 x 32	75-150	19,500
UM04	40 x 29	27 x 32	60-100	16,600
	Diameter x Width	Width x Height		
Model	Rotor (Inches)	Feed Opening (Inches)	Power Required (HP)	Approx. Weight (Lbs)

Aggregate • Sand & Gravel • C&D Debris • Recycle Concrete • Recycle Asphalt
 P.O. Box 537, Galion, OH 44833 • 419-468-2288 • fax: 419-468-4840 • email: sales@eaglecrusher.com

Call 800-25-EAGLE
 or visit www.eaglecrusher.com