

# 500-05CC

## Highly Portable Closed-Circuit Plant

Increase your profitability with the highly portable UltraMax® 500-05CC crushing plant. With its onboard screen, the UM 500-05CC produces two Superpave products simultaneously. This plant is ideal for a wide variety of aggregate and recycle materials, including recycled asphalt. The UltraMax 500-05CC features a solid-steel, 3-bar rotor backed by the industry's first 5-year rotor guarantee.

## 500-05CC *QuikSpecs*®

- Built-in hydraulic lift/leveling system delivers quick set-up and tear-down
- Environmentally tight product design reduces dust during operation
- The solid-steel, 3-bar rotor easily handles limestone and sand & gravel feed material with reduction ratios up to 24:1
- On-board 325 HP diesel engine with 100 kW generator powers all plant functions
- 16' x 32" vibrating grizzly feeder features a 5' tapered step grizzly design
- 4' x 12' integral double-deck screen provides simultaneous production of 2 cubical spec products
- Backed by the industry's first 5-year rotor guarantee
- Hydraulic-opening impactor housing offers unobstructed access to crushing chamber and secondary curtain adjustment
- Remote operator's station mounted on operator's platform

\*\* See reverse side for details



UltraMax® 500-05CC



**ULTRAMAX® IMPACTORS**

**500-05CC Travel Dimensions**

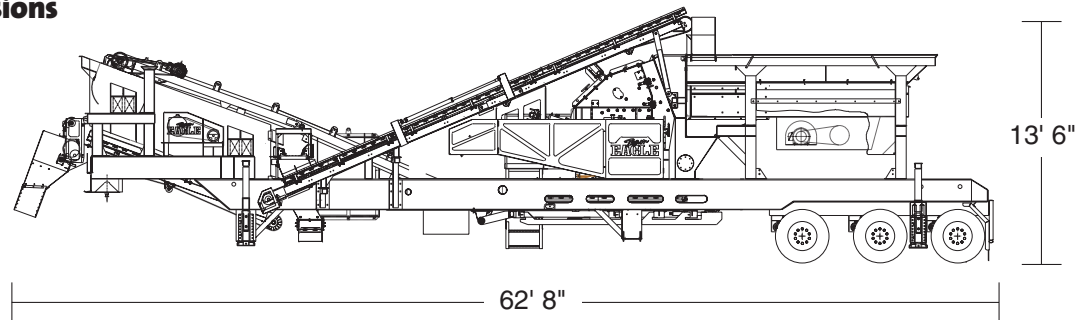

**500-05CC Portable Plant Specifications\***

<b>Impactor</b>	3-stage UltraMax® UM05
<b>Impactor Weight</b>	19,500 lbs.
<b>Plant Weight</b>	90,500 lbs.
<b>Travel Width</b>	11'
<b>Rotor Diameter &amp; Width</b>	40" x 33"
<b>Feed Opening</b>	33" x 32"
<b>Vibrating Grizzly Feeder Dimensions</b>	16' x 32"
<b>Feed Hopper Capacity</b>	9 cubic yards/12 tons
<b>Grizzly Bars</b>	Two-step, 30" long bars with various spacing
<b>On-Plant Screen</b>	4' x 12' double-deck
<b>On-Plant Power Supply</b>	325 HP diesel engine and 100 kW generator
<b>Hydraulic Lift/Leveling System</b>	On-board, gas-powered; also used for secondary curtain settings and crushing chamber access

\* Design specifications subject to change without notice.

**UltraMax® Impactor Models and Specifications**

<b>UM69</b>	56 x 68	69 x 42	400-600	60,200
<b>UM45</b>	50 x 56	56 x 35	300-400	38,700
<b>UM25</b>	47 x 47	48 x 34	150-300	32,500
<b>UM15</b>	44 x 41	42 x 32	150-200	27,500
<b>UM05</b>	40 x 33	33 x 32	75-150	19,500
<b>UM04</b>	40 x 29	27 x 32	60-100	16,600
	Diameter x Width	Width x Height		
<b>Model</b>	<b>Rotor</b> (Inches)	<b>Feed Opening</b> (Inches)	<b>Power Required</b> (HP)	<b>Approx. Weight</b> (Lbs)

**ATTENTION:** Eagle Crusher Company designs a range of impactors. The capacities vary based on feed size, feed rate, physical characteristics of feed material, environmental conditions, operator training and proficiency, blow bar gap settings, and conditions of wear parts.