

1000-15CV

Open-Circuit Crushing/ Recycling Plant

The UltraMax® 1000-15CV is ideal for frequent site changes and sizeable production. The self-contained plant handles large feed materials with ease and is extremely portable. The UltraMax 1000-15CV offers a 42" x 32" feed opening. In addition, the plant features a solid-steel, 3-bar rotor backed by Team Eagle's 5-year rotor guarantee — the first guarantee of its kind in the industry.

1000-15CV *QuikSpecs*®

- Powerful on-board 325 HP diesel engine with 75 kW generator to operate all package components
- 11-cubic yard feed hopper easily accepts aggregate or recycle material from 3.5 to 5-yard loader buckets or excavator
- Adjustable primary and secondary curtains allow precise product gradation control
- Backed by the industry's first 5-year rotor guarantee
- Hydraulic-opening impactor housing offers unobstructed access to crushing chamber and secondary curtain adjustment
- Remote operator's station mounted on operator's platform



UltraMax® 1000-15CV



“On the Eagle system, everything is self-contained...once we move into a site, we can probably be crushing in 3 hours.”

Richard Zerkel, Vice President of Equipment and Maintenance
Adams Contracting



ULTRAMAX® IMPACTORS

Product Specification Sheet
1000-15CV Portable Plant Specifications

EAGLE CRUSHER
 COMPANY, INCORPORATED

1000-15CV Travel Dimensions

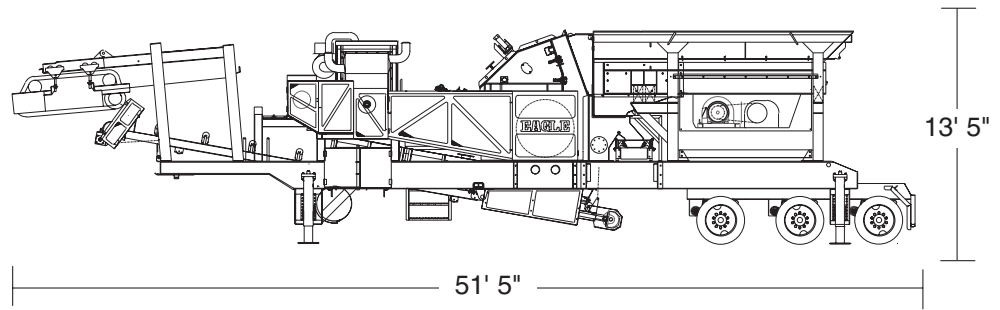

1000-15CV Portable Plant Specifications*

Impactor	3-stage UltraMax® UM15
Impactor Weight	27,500 lbs.
Plant Weight	87,600 lbs.
Travel Width	11' 11"
Rotor Diameter & Width	44" x 41"
Feed Opening	42" x 32"
Vibrating Grizzly Feeder Dimensions	16' x 39" with 5' tapered step grizzly
Feed Hopper Capacity	11 cubic yards/14 tons
Grizzly Bars	Two-step, 30" long bars with various spacing
Discharge System	36" wide conveyor
On-Plant Power Supply	275 HP diesel engine and 75 kW generator
Hydraulic Lift/Leveling System	On-board, gas-powered; also used for secondary curtain settings and crushing chamber access

*Design specifications subject to change without notice.

UltraMax® Impactor Models and Specifications

UM69	56 x 68	69 x 42	400-600	60,200
UM45	50 x 56	56 x 35	300-400	38,700
UM25	47 x 47	48 x 34	150-300	32,500
UM15	44 x 41	42 x 32	150-200	27,500
UM05	40 x 33	33 x 32	75-150	19,500
UM04	40 x 29	27 x 32	60-100	16,600
	Diameter x Width	Width x Height		
Model	Rotor (Inches)	Feed Opening (Inches)	Power Required (HP)	Approx. Weight (Lbs)

ATTENTION: Eagle Crusher Company designs a range of impactors. The capacities vary based on feed size, feed rate, physical characteristics of feed material, environmental conditions, operator training and proficiency, blow bar gap settings, and conditions of wear parts.

Aggregate • Sand & Gravel • C&D Debris • Recycle Concrete • Recycle Asphalt
 P.O. Box 537, Galion, OH 44833 • 419-468-2288 • fax: 419-468-4840 • email: sales@eaglecrusher.com

Call 800-25-EAGLE
or visit www.eaglecrusher.com